



- 12 Configurable Inputs and Outputs
- Wide choice of communications options
- ISaGRAF 61131-3 ready (order CC030A-URTT to activate)
- Integrated Solar Charger or 10-30Vdc
- SD Memory Card Logging
- Modbus support
- Very low power operation



### Features

- 10 - 30V dc or direct solar powered.
- Low power consumption for battery applications
- 12 Inputs and/or Outputs (Analogue or Digital)
- SD Memory Card Slot for off-line data logging.
- On-board temperature sensor and voltage monitor

- Integral Real-Time Clock with Battery Backup
- Programmable for a wide range of applications.
- Wide operating temperature range
- Compact size for tight spaces
- Convenient DIN Rail or surface mounting

### Overview

The **Teleterm M3** is a state-of-the-art range of RTU's range designed to expand the possibilities of remote monitoring and control by providing a cost effective platform with a wide range of features.

### Communication

Communications options include GSM/GPRS or EDGE/HSPA UMTS, 4G, CDMA and, 868MHz and 900MHz licence free radio bands, and RS232 and RS485 serial ports.

### Inputs

The Teleterm M3 comes with 12 universal I/O that can be configured for analogue or digital input or output according to your needs.

### Built in RS232/485 port

The on board RS232/485 ports can be used to acquire data from other third party devices using the Modbus protocol, or by downloading a custom software protocol "plug-in". This feature allows a wide variety of third party devices to be supported.

### Low Power Consumption

The low power consumption of the Teleterm M3 makes it suitable for use in solar powered and battery powered applications. A solar regulator is built into the Teleterm M3.

### Programming

The Teleterm M3 series can be programmed in the optional ISaGRAF, an industry standard programming environment

for all five IEC61131-3 programming languages, providing the ability to do local control, and custom logic.

### Built-in Data Logging

The Teleterm M3 also incorporates a microSD memory card slot to support local data logging.

### Typical Applications

Typical Applications for the M3 include:

- Remote Site Monitoring
- Remote Meter Reading.
- Environmental Monitoring
- Remote Valve Control
- Flow monitoring
- Reservoir Level Monitoring
- Irrigation Monitoring and Control
- Tank Level Monitoring





### General Layout

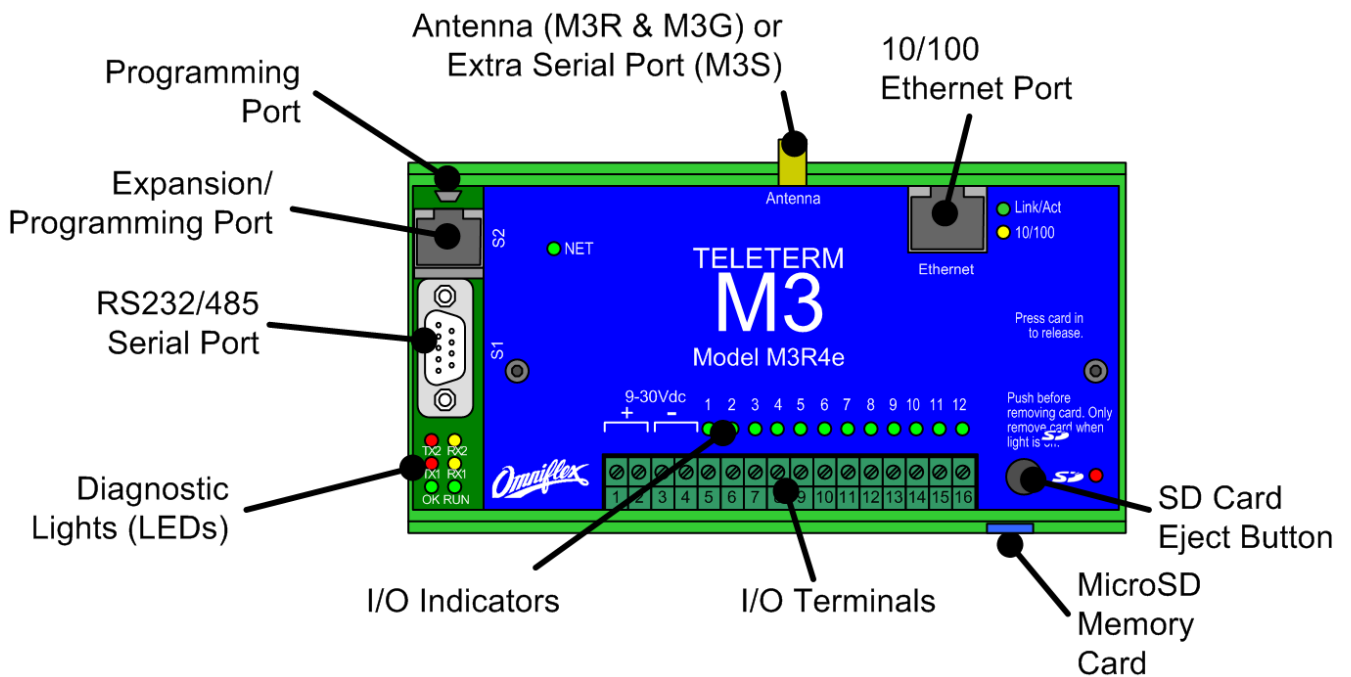

### Mechanical Dimensions

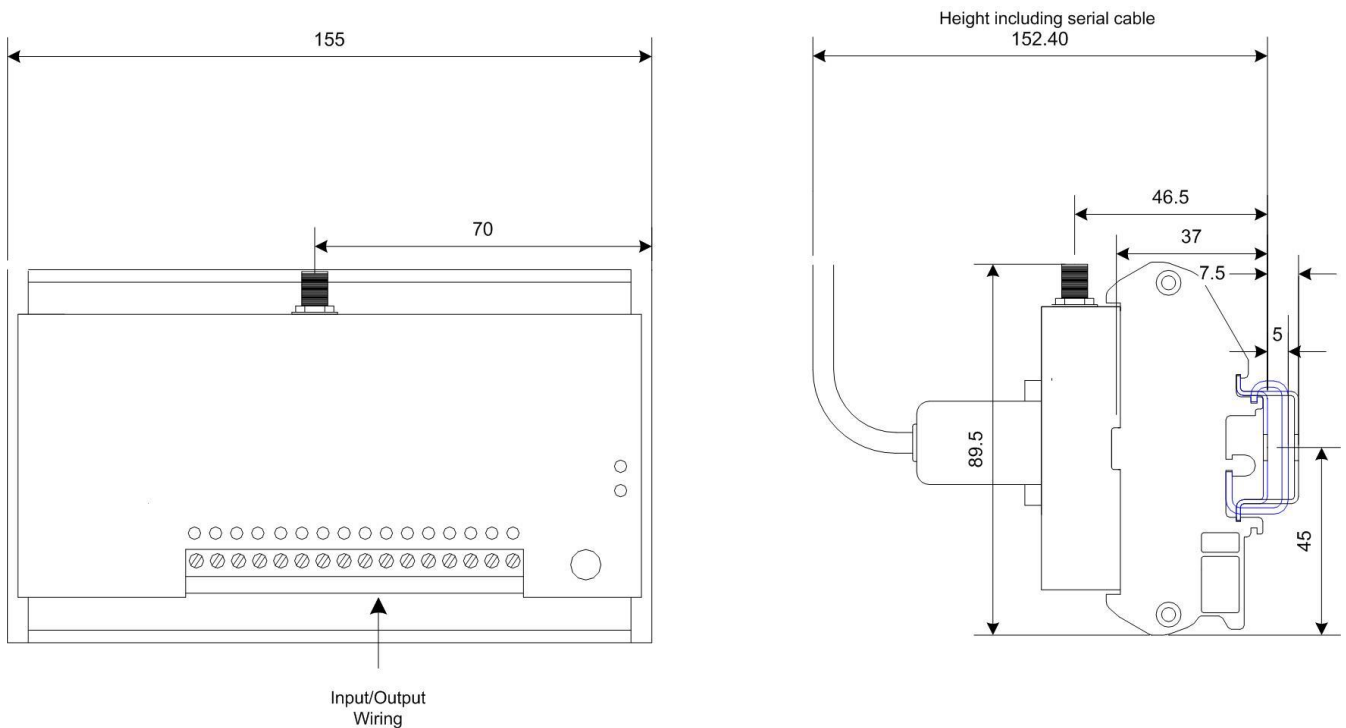



Communications Options by Model

Product Name	Order Code	Notes	12 I/O	10/100 Ethernet	RS232 Port	RS232/RS485 Port	4G/LTE CAT1 Port	5G Cat M1/NB2	2.4GHz 63mW Radio Port	868MHz 10mW Radio Port	868MHz 500mW Radio Port	920MHz 1W Radio Port	+1 RS232/RS485 Port
M3e	C2363A-0		<input checked="" type="checkbox"/>	<input checked="" type="checkbox"/>	<input checked="" type="checkbox"/>	<input checked="" type="checkbox"/>							
M3G4e	C2363A-141	1,2	<input checked="" type="checkbox"/>	<input checked="" type="checkbox"/>	<input checked="" type="checkbox"/>	<input checked="" type="checkbox"/>	<input checked="" type="checkbox"/>						
M3G4e	C2363A-142	1,3	<input checked="" type="checkbox"/>	<input checked="" type="checkbox"/>	<input checked="" type="checkbox"/>	<input checked="" type="checkbox"/>	<input checked="" type="checkbox"/>						
M3G5	C2363A-151	1,4	<input checked="" type="checkbox"/>	<input checked="" type="checkbox"/>	<input checked="" type="checkbox"/>	<input checked="" type="checkbox"/>		<input checked="" type="checkbox"/>					
M3R1e	C2363A-301	5,6	<input checked="" type="checkbox"/>	<input checked="" type="checkbox"/>	<input checked="" type="checkbox"/>	<input checked="" type="checkbox"/>			<input checked="" type="checkbox"/>				
M3R2	C2363A-302	5,8	<input checked="" type="checkbox"/>	<input checked="" type="checkbox"/>	<input checked="" type="checkbox"/>	<input checked="" type="checkbox"/>				<input checked="" type="checkbox"/>			
M3R4e	C2363A-304	5,7	<input checked="" type="checkbox"/>	<input checked="" type="checkbox"/>	<input checked="" type="checkbox"/>	<input checked="" type="checkbox"/>						<input checked="" type="checkbox"/>	
M3R6	C2363A-306	5,8	<input checked="" type="checkbox"/>	<input checked="" type="checkbox"/>	<input checked="" type="checkbox"/>	<input checked="" type="checkbox"/>					<input checked="" type="checkbox"/>		
M3S1e	C2363A-401	9	<input checked="" type="checkbox"/>	<input checked="" type="checkbox"/>	<input checked="" type="checkbox"/>	<input checked="" type="checkbox"/>							<input checked="" type="checkbox"/>

NOTES:

1. The M3G version is available in a number of options to conform to different GSM based networks. Please ensure that the correct unit is specified for your application.
2. The 4G/LTE port is a CAT1 interface operating on bands B1/B3/B7/B8/B20 and B28A. This is suitable for use in Europe, and South Africa. Consult the factory for specific compatibility with your region's network.
3. The 4G/LTE port is a CAT1 interface operating bands B1/B3/B5/B7 and B28. This is suitable for use in Australia and New Zealand. Consult the factory for specific compatibility with your region's network.
4. The 5G/LTE is a CAT1 interface operating on bands B1, B2, B3, B4, B5, B8, B12, B13, B18, B19, B20, B25, B26, B28, B66, B71 and B85. This is suitable for use in multiple regions. Consult the factory for specific compatibility with your region's network.
5. The M3R versions are available in a number of radio band options to comply with different country regulations. Please ensure that the correct unit is specified for your application.
6. 2.4GHz Band is suitable for all countries – short range only
7. 920MHz Band is suitable for use in USA, Australia and New Zealand.
8. 868MHz Band is suitable for use in Europe, and South Africa.
9. Although both an extra RS232 DB9 connector AND an RS485 Molex connector are provided in this version, only ONE can be in use at any ONE time.





## Input/Output Configurable Options

The M3 is equipped with 12 versatile input/output points (I/O points or IOP's). Each I/O point can be individually configured from the options given in the following table:

I/O Point	Terminal (n)o.	Digital Input	Analogue Input	Digital Output	Analogue Output
1	5	Yes	0-30Vdc	Yes	-
2	6	Yes	0-30Vdc	Yes	-
3	7	Yes	0-5Vdc	Yes	-
4	8	Yes	0-5Vdc	Yes	-
5	9	Yes	0-5Vdc	Yes	-
6	10	Yes	0-5Vdc	Yes	-
7	11	Yes	0-5Vdc	Yes	-
8	12	Yes	0-5Vdc	Yes	-
9	13	Yes	0-5Vdc	Yes	-
10	14	Yes	0-5Vdc	Yes	-
11	15	Yes	0-30Vdc	-	0/4-20mA
12	16	Yes	0-30Vdc	-	0/4-20mA

**Note 1:** See the "Specifications" section of this document for detailed specifications of each I/O point option.

**Note 2:** All 0-30V analogue inputs have increased resolution over the range 0-6V (equivalent to the 0-5V inputs).

**Note 3:** All Digital Inputs can be configured as Pulse Counters or Hours Counter.

**Note 4:** All Digital Outputs can be configured as Pulse outputs (normally ON or normally OFF).

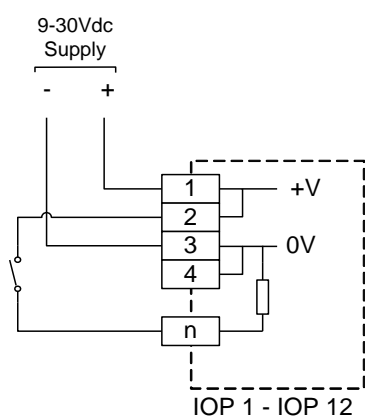

DIGITAL INPUTS

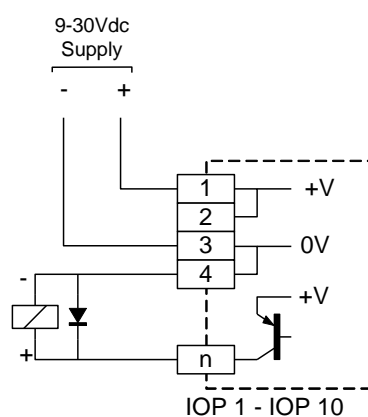

DIGITAL OUTPUTS

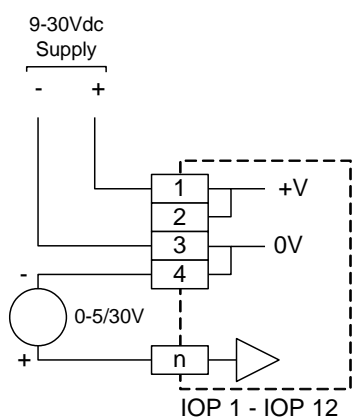

ANALOGUE INPUTS

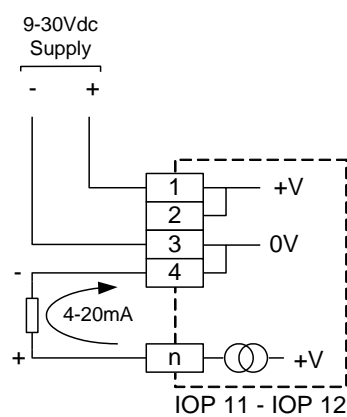

ANALOGUE OUTPUTS



## Specifications

### Inputs/Outputs

All M3 RTU's have 12 Input/Output Points (IOP configurable in software as analogue or digital, inputs or outputs.)  
(See the table above for a matrix of available functions for each I/O Point.)

#### As a Digital Input (10 Points 1 to 12)

Type	Current Sink (Switch to +V to operate)
Input Impedance	5 kOhms nominal.
Input OFF Condition	Input < 2Vdc
Input ON Condition	Input > 3Vdc
Functions	Software selectable as: ON/OFF Status Counter Input (counts OFF to ON transitions at 50Hz max). Hours Input (counts hours while input is ON to resolution of 0.01 hours).

#### As a Digital Output (10 Points 1 to 10)

Type	Voltage Source (Solid State Switch to +V)
ON State Rated Current	< 100mA continuous maximum per output < 200mA peak (<10ms) max, per output < 500mA total for all outputs simultaneously
ON State Voltage	< 3V at maximum rated load
OFF State Current	< 0.1mA at maximum supply voltage
Functions	Software selectable as: ON/OFF ON Pulse (configurable 10ms – 300s) OFF Pulse (configurable 10ms = 300s)

#### As an Analogue Input (I/O Points 1,2,11,12)

Type	Voltage Input referenced to 0V supply.
Range	0-30Vdc (software configurable to smaller ranges such as 1-5Volts)
Accuracy	< 0.15% of reading +6mV from 0 - 5.5V < 0.15% of reading +30mV from 5.5 - 30V
Resolution	6mV from 0 to 5.5 Volts nominal (10 bits) 33mV from 5.5 to 30Volts nominal (10 bits)
Digital Filtering	16 bit resolution enhanced low pass

#### As an Analogue Input (I/O Point 3 - 10)

Type	Voltage Input referenced to 0V supply.
Range	0-5.5Vdc (software configurable to smaller ranges such as 1-5Volts)
Accuracy	< 0.25% of reading +6mV
Resolution	6mV nominal (10 bits)
Input Termination	250 ohms (software selectable)
Digital Filtering	16 bit resolution enhanced low pass

#### As an Analogue Output (I/O Points 11 and 125)

Type	0-25mA Source into 0V connected load
------	--------------------------------------

Load	>20V over 0-25mA for any supply voltage
------	---

Load	Calculate maximum load as follows: $R_{max} = (V_{supply} - 5V) \div .02 \text{ Ohms}$ Examples: 11V Supply: $R_{max} = 300 \text{ Ohms}$ 13.8V Supply: $R_{max} = 440 \text{ Ohms}$ 22V Supply: $R_{max} = 300 \text{ Ohms}$ 24V Supply: $R_{max} = 950 \text{ Ohms}$ 27.6V Supply: $R_{max} = 1130 \text{ Ohms}$
Maximum Range	0 to 23 mA (software configurable to smaller ranges such as 4-20mA or 0-10mA)

### General Specifications

#### Power Requirements

Power Supply Voltage	9 – 30Vdc (ripple < 5%)
Average Current	80mA at 12Vdc    40mA at 24Vdc
Average Current (Sleep Mode)	0.25mA over 9-30Vdc

#### IEC61131-3 Programming (Optional)

Six graphical Languages	SFC – Structured Flow Chart FC – Flow Chart FBD – Function Block LD – Ladder Diagram ST – Structured Text IL – Instruction List
Programming Environment	Windows PC based "Omniflex ISaGRAF Application Workbench"

#### Environmental Conditions

Storage Temperature	-25°C – 85°C (-13°F – 185°F)
Operating Temperature	-10°C – 60°C (+14°F – 140°F)
M3G Radio compliance	-10°C – 50°C (+14°F – 122°F)

#### Mechanical

Mounting	DIN rail, G Rail Surface mount with kit C0010A
Dimensions	155 x 89.5 x 59.5 mm

#### Weight

Packed/Unpacked	350gm/250gm approx.
-----------------	---------------------

#### Processor

Type	Dual Core 16 Bit Processor
Clock Speed	72MHz
Memory – Flash /RAM	1MB /512kB

#### Real Time Clock

Resolution	10ms
Accuracy	1 min per month
Battery Life	> 1 year with power off





# Teleterm M3 Programmable RTUs

RTU with integrated communication ports and Ethernet

Model Number  
**C2363A**

	> 5 years with power on.
Battery Type	3V Lithium Cell type CR2032
<b>Compliance with Standards</b>	
Safety	EN 60950
Emissions	EN 55011, Group I, Class A
Immunity – ESD	IEC 61000-4-2:2001, level 3
Immunity – RF Fields	IEC 61000-4-3:2003, level 3
Immunity – Fast Transients	IEC 61000-4-4:2004 2 kV – DC power port 1 kV – input/output lines

## Front Panel Serial Port ( available on all models )

Type	Asynchronous serial port
Protocols	Supports the following protocols as standard: <ul style="list-style-type: none"> <li>• Conet/s</li> <li>• Modbus ASCII (Master or Slave)</li> <li>• Modbus RTU (Master or Slave)</li> </ul> Other protocols “plugins” may be downloaded.
Baud Rate	300 – 38,400 baud.
Maximum cable length	15 meters (50ft) in RS232 mode 1200m (4000ft) in RS485 mode
Connection	9 pin sub-miniature DB9 (male).
RS232/422/485	Selected by the wiring to the DB9 connector

Pin	Communication Standard	
	RS232	RS485
1	Do not connect	Rx Data + (In)
2	Rx Data (In)	Rx Data – (In)
3	Tx Data (Out)	Do not connect
4	Do not connect	Tx Data+ (Out)
5	Ground	Ground
6	Do not connect	Vcc
7	RTS (Out)	Do not connect
8	CTS (In)	Do not connect
9	Do not connect	Tx Data – (Out)

\* Tx+ and Rx+ (pins 1 and 4) need to be connected together as do Tx- and Rx (pins 2 and 9) when using RS485 2-wire.

## Extra Serial Port Version

Available only on Teleterm M3S1e Model C2363A-41

### Serial Port

Type	1 x RS232 OR 1 x RS485 <b>Note:</b> EITHER the RS232 DB9 connector OR the RS485 Molex connector can be used in the Extra Serial Port version
------	---

### RS232 Connector

Type	9 pin sub-miniature male (DB9M).
Serial Protocols supported	Supports Conet/s and Modbus ASCII and RTU – Master or Slave as standard, but other protocols may be downloaded.

	(Consult the factory for advice on additional protocols)
Baud Rate	300 – 38,400 baud.
Maximum cable length	15 meters (50ft) in RS232 mode

PIN	I/O	RS232	DESCRIPTION
1	I	CD	Carrier Detect
2	I	RD	Receive Data
3	O	TD	Transmit Data
4	O	DTR	Data Terminal Ready
5	-	SG	Signal Ground
6	I	DSR	Data Set Ready
7	O	RTS	Request To Send
8	I	CTS	Clear To Send
9	I	RI	Ring Indicator

### RS485 Connector

Type	Molex Type 7478 (3 pins)
Serial Protocols supported	Supports Modbus ASCII and RTU – Master or Slave as standard, but other protocols may be downloaded. (Consult the factory for advice on additional protocols)
Baud Rate	300 – 38,400 baud.
Maximum cable length	1200m (4000ft) in RS485 mode

Pin	Name	Description
17	0V	0V Line (if used)
18	RS485-	RS485- line
19	RS485+	RS485+ line

**Note:** Although both an extra RS232 DB9 connector AND an RS485 Molex connector are provided in this version, only ONE can be in use at any ONE time

## Plug-in Memory Card ( available on all models )

Type	micro SD Memory Card (15mm x 11mm x 1.0mm)
Storage Capacity	SD Memory Card dependent: Up to 2Gb supported
Card Format	PC Compatible FAT File Format
Data Format	Data writable by user program to suit application. Any text based file format may be written such as CSV File Format compatible with Microsoft Excel etc.

## Mobile Network Communication Specifications

### Teleterm M3G4 Module C2363A-141 (LTE [EMEA])

Region/Operator	EMEA/UK/Thailand
Type	LTE Cat 1 mobile network
Network Bands	Small (3 Volt only)
Regulatory Approvals	Global: GCF Europe: CE Taiwan (China): NCC Australia/New Zealand: RCM
SIM Card	3Volt Standard SIM
Antenna	External via SMA connector.





# Teleterm M3 Programmable RTUs

RTU with integrated communication ports and Ethernet

Model Number  
**C2363A**

## Teleterm M3G4 Module C2363A-142 (LTE [AUS/NZ])

Region/Operator	Latin America/Australia/New Zealand
Type	LTE Cat 1 mobile network
Network Bands	LTE-FDD: B1/B2/B3/B4/B5/B7/B8/B28 LTE-TDD: B40 WCDMA: B1/B2/B5/B8 GSM/EDGE: B2/B3/B5/B8
Regulatory Approvals	North America: FCC Canada: IC Brazil: Anatel Taiwan (China): NCC Japan: JATE/TELEC Australia/New Zealand: RCM
SIM Card	3Volt Standard SIM
Antenna	External via SMA connector.

## Teleterm M3G5 Module C2363A-151 (5G/LTE)

Region/Operator	Multi-Region
Type	LTE Cat M1/NB2 mobile network
Network Bands	B1, B2, B3, B4, B5, B8, B12, B13, B18, B19, B20, B25, B26, B28, B66, B71, B85
SIM Card	3Volt nano SIM
Approvals	FCC, ISED, GCF, PTCRB, Verizon, AT&T, US Cell, T-Mobile, Telus, Rogers 3, RED, Vodafone 3, Deutsche Telekom 3, KCC 3, SKT 3, Giteki, Softbank 3, KDDI 3, RCM, Telstra, ICASA 3, NCC
Antenna	External via SMA connector.

## Radio Network Communications Specifications

### Teleterm M3R1e Module C2363A-301 (2.4GHz 63mW)

Operating Band	ISM 2.4GHz
Special Radio Licence Requirements	None. (operates in licence-free ISM band)
Transmit Power	63mW (+18dBm)
Receiver Sensitivity	-100dBm typical
Modulation	DSSS FSK
RF Data Rate	250 000 bits per second
Throughput Data Rate	9600 bits per second 10% duty cycle
Outdoor Range (Urban) (Line of Sight)	90m 1.6km
Antenna	RPSMA Connector for external antenna
Approvals	Approved for use internationally

### Teleterm M3R2 Module C2363A-302 (868MHz 10mW)

Operating Band	SRD g3 Band (869.525 MHz)
Special Radio Licence Requirements	None. (operates in licence-free ISM band)
Transmit Power	10mW (+10dBm)
Receiver Sensitivity	-109dBm typical
Modulation	FSK
Throughput Data Rate	1,200 to 19,200 bits per second 10% duty cycle LBT (Listen Before Talk)
Number of Channels	Three Channels
Operating Band	SRD g3 Band (869.525 MHz)
Outdoor Range (Urban) (Line of Sight)	Up to 3 km with dipole Up to 6 km with hi-gain antenna
Antenna	RPSMA Connector for external antenna
Approvals	Approved for use in Europe and S.Africa

### Teleterm M3R4e Module C2363A-304 (920MHz 1W)

Operating Band	915-928 MHz
Special Radio Licence Requirements	None. (operates in licence-free ISM band)
Transmit Power	Settable 1mW (0dBm) to 1W(+30dBm)
Receiver Sensitivity	-110dBm typical
Modulation	FHSS FSK
Throughput Data Rate	9,600 bps / 128kbps (selectable)
Number of Channels	10 Frequency Hopping Sequences
Outdoor Range (Line of Sight)	Up to 10 km with dipole Up to 30 km with hi-gain antenna
Antenna	RPSMA Connector for external antenna
Approvals	Approved for use in USA and Australia

### Teleterm M3R6 Module C2363A-306 (868MHz 500mW)

Operating Band	SRD g3 Band (869.525 MHz)
Special Radio Licence Requirements	None. (operates in licence-free ISM band)
Transmit Power	Settable 1mW (0dBm) to 500mW(+27dBm)
Receiver Sensitivity	-109dBm typical
Modulation	FSK
Throughput Data Rate	1200 bps to 19200kbps (selectable), 10% duty cycle LBT (Listen Before Talk)
Number of Channels	Up to 10 channels (depending on baud rate)
Outdoor Range (Line of Sight)	Up to 20 km with dipole Up to 40 km with hi-gain antenna
Antenna	RPSMA Connector for external antenna
Approvals	Approved for use in Europe and South Africa





## Ordering Information

ORDER CODE	PRODUCT	DESCRIPTION
C2380C-0	Teleterm M3 <sup>#</sup>	Teleterm M3 Programmable RTU
C2363A -141	Teleterm M3G4 <sup>#</sup>	Teleterm M3G4 Programmable RTU equipped with 10/100 Ethernet Port and integral GSM internal modem.4G (UK/EU/SA)
C2363A -142	Teleterm M3G4 <sup>#</sup>	Teleterm M3G4Programmable RTU equipped with 10/100 Ethernet Port and integral GSM internal modem (4G) AU/NZ
C2363A-151	Teleterm M3G5 <sup>#</sup>	Teleterm M354Programmable RTU equipped with 10/100 Ethernet Port and integral GSM internal modem LTE-M/NB2 Port
C2363A-301	Teleterm M3R1e <sup>#</sup>	Teleterm M3R1e Programmable RTU equipped with 10/100 Ethernet Port and integral 2.4GHz 63mW licence-free radio network port (available internationally – short range)
C2363A-302	Teleterm M3R2 <sup>#</sup>	Teleterm M3R2 Programmable RTU equipped with 10/100 Ethernet Port and integral 868MHz 10mW licence-free radio network port (Europe (CE) and South Africa only)
C2363A-304	Teleterm M3R4e <sup>#</sup>	Teleterm M3R4e Programmable RTU equipped with 10/100 Ethernet Port and integral 900MHz 1W FHSS licence-free radio network port (USA, Australia only)
C2363A-306	Teleterm M3R6 <sup>#</sup>	Teleterm M3R6 Programmable RTU equipped with 10/100 Ethernet Port and integral 868MHz 500mW (Europe, Middle East, Africa only)
C2363A-401	Teleterm M3S1e <sup>#</sup>	Teleterm M3Se Programmable RTU equipped with 10/100 Ethernet Port and second and third RS232/485 serial ports.
CC030A-URTT	ISaGRAF Initiation	# Order to activate ISaGRAF programming which conforms to IEC61131-3

## Accessories

M1831B	MX Programming Cable	RS232 Male DB9 connector (PC end) to FC11 (Target end) 2 metres (Used to convert Serial Port 2 to DB9).
M1833A	MX RS232/485 Serial Patch Cable	RS232/485 Female DB9 connector (M3 end) to loose ends. 2 metres.
M1838A	MX Prog Adapter	USB to MiniB Plug for Teleterm Range with MiniB Programming Port