

**in this issue:**

**page 1**

www.omniflexdirect.com...  
now on the web

<http://www.omniflex.com>

**page 2**

**Its Showtime Folks -**  
Omniflex continues to  
exhibit at various  
international shows

**Omni-16 gets Modbus  
Interface -** brand new  
product which puts your  
annunciator data on your  
PLC, DCS or SCADA

**page 3**

**Maxiflex T1 CPU -** the most  
versatile CPU for Maxiflex  
ever, saves you weeks of  
work and gets your networks  
talking.

**ConetRouterWizard -**  
amazing Excel spreadsheet  
that takes the sweat out of  
configuring multiple Conet  
networks.

**page 4**

**Two of our Adverts -** not  
full size

**Maxiflex Flow Monitoring  
System -** pulse totalisation  
for PLCs and DCSs up to  
10km over a Conet LAN

**Memory Lane -** Products  
from 1975 to 1996



OmniWatch

OmniFlex - 24/365

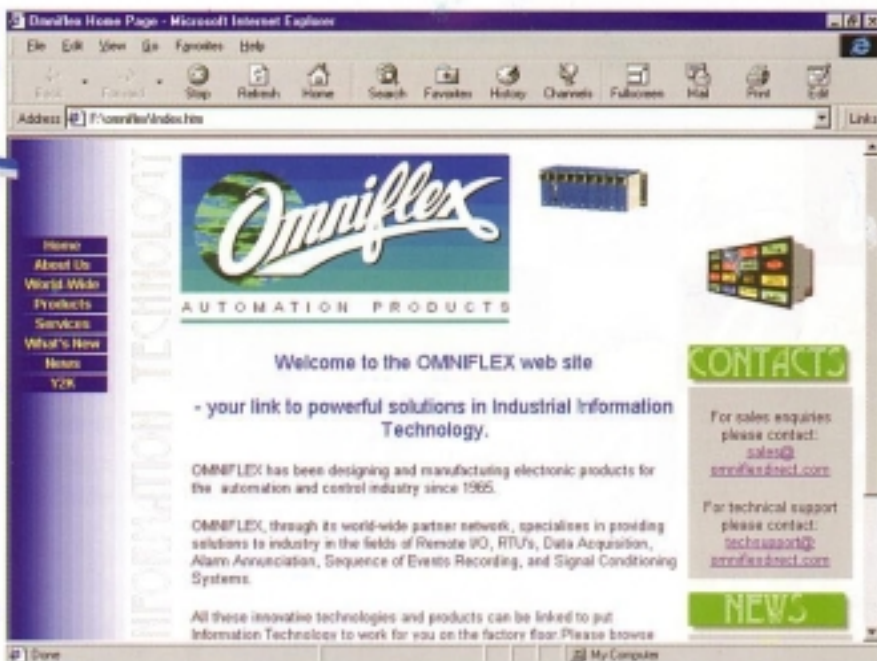

Visit our new website...

We're on the web now as OmniflexDirect, a no-brainer indicator of the way the global business is developing and a site that 'belongs' to our worldwide user community. Its yours - 24 hours a day, 365 days a year.

For distributors and clients in different time-zones, the web provides the ideal vehicle for sharing information and for checking out the latest products, technologies, applications, press releases, technical literature and other bits and pieces which will be posted.

On the site you will find a list of all international distributors and offices for quick and easy contact. Often the answers to

specific challenges will come from distributors and users and not just the team at Omniflex.

Check out the Downloads section as we will post more and more stuff here for you to print and use. Adobe Acrobat is our favoured file format as this suits all international distributors and users.

You can contact us from the website directly and you will also be able to register as a user for our different products. The feedback form will allow you to tell us what you think and if its 'hot', it could be published in the next issue of OmniFacts.

Watch this space...



Some of the team enjoying a break. From L-R: Tadek, Dave, Danny, Ian, Raj, Dan, Tony, Loftly and Suman

APRIL  
Issue Three





# It's Showtime Folks...

## International Exhibitions

We continue to exhibit our evolving product range at key international exhibitions and functions around the world, as follows. These exhibitions allow you to view the latest products and to meet our regional distributors in person.

EXHIBITION	PLACE	DATES
Drives & Controls	Birmingham, UK	March 1999
Electrex Inst. & Control '99	Richards Bay, SA	24, 25 March 1999
Process Industries Show	Cape Town, SA	May 1999
Automate	Sydney, Aus	October 1999

We will be showing the following products and technologies:



Maxiflex - programmable IO system and RTU



ConetRouterWizard - new Excel Spreadsheet tool for configuring Conet Intranets. Check this out.

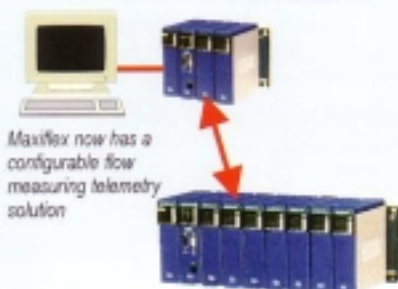

Maxiflex now has a configurable flow measuring telemetry solution

OmniWatch - 5-in-1 Machine Monitoring System that eliminates the need for separate instruments in manned and unmanned applications.



Omni-16 - world's best alarm annunciator, now upgraded with a Modbus interface so your alarms can be processed by the PLC or DCS.



Maxiflex NIMs for connection to almost any plant device



Powerterms - great new range of enclosed 12/24Vdc instrument power supplies. More power, less money.

# Modbus for Omni-16...

The interface you've all been waiting for

Following numerous requests from users for an interface that enables Omni-16 alarm annunciator statuses to be sent directly to a PLC, DCS or SCADA, we have released a range of DIN rail mount modules that effectively turn the Omni-16 into a Modbus Slave device.



DIN Rail Mounted Modbus Interface for Omni-16 - the world renowned alarm annunciator

The Modbus Interface Modules have a single DIP switch used to set the address, the mode (RTU or ASCII), the baud rate and parity. Using the modules in RS485 mode, enables 32 Omni-16s (512 alarm channels) to be monitored from a single Master Modbus equipped serial port.

The Modbus module is connected to the Omni-16 repeat outputs header via a ribbon cable and also provides full isolation for industrial strength communications in noisy environments. A single 16-bit register reflects the status of the alarm inputs in the annunciator while the Omni-16's 24Vdc power supply is used to power the module too.

Also available is a general purpose Modbus Digital Input module which accepts 16 switch inputs and does exactly the same as the Omni-16 Modbus Module. This can be linked to the same RS485 network as the Omni-16s for accepting general purpose contacts or pushbutton inputs etc.

All modules have LED indicators which indicate send/receive data transmission statuses. The modules support 300, 1200, 9600 and 19200 baud rate transmissions, fast enough for any alarm annunciation application.

## MODBUS INTERFACE MODULES FOR OMNI-16 ANNUNCIATORS

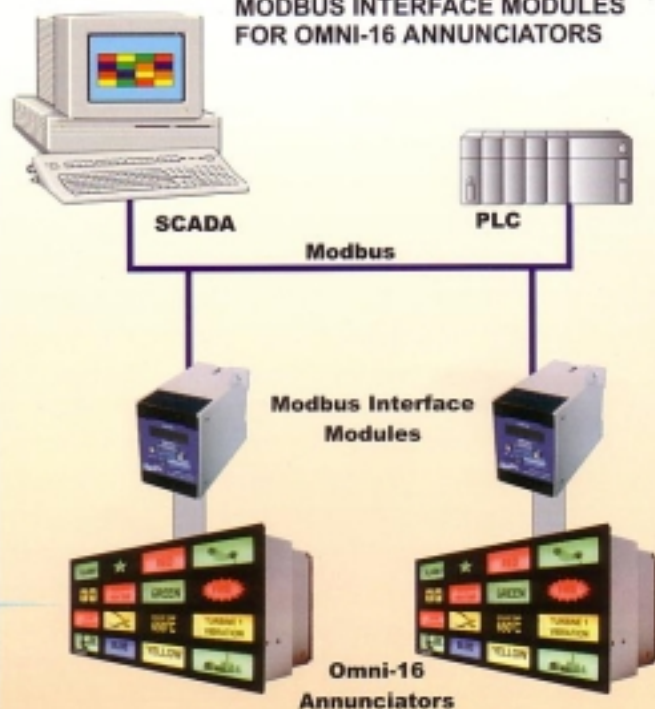



# Maxiflex TI - the Well Connected CPU

## The most versatile Maxiflex CPU ever produced



The new T1 CPU is designed specifically for Remote I/O, offering 4 major new features in a combination of technologies that significantly enhance functionality, user-friendliness and value to the user. By retaining all of the previous generation CPU functionality, the new T1 is 100% backwards compatible for existing systems.

### 1. Enhanced Data Access through Virtual DIT

The Data Interchange Table (DIT) has been increased from 4000 to 64 000 registers, with each I/O slot now allocated 4000 registers. Thus the network can read and write all I/O and configuration parameters directly without the need for any user programming. Thus complete data within a Maxiflex rack, right down to I/O level, is totally available to the network.

### 2 Internetwork Routing

Following the ISO OSI 7-layer model, new developments in the network layer have resulted in an enormously powerful facility for reaching right down to the factory floor in very large, geographically spread out installations. While there is so much debate going on over which Fieldbus to use, Conet has taken internetworking to a new level and the T1 CPU, together with Network Interface Modules (NIMs) provide an unbeatable "Zero Programming" combination.

The internetworking feature very simply means that the T1 CPU has a built-in router which enables you to link many dissimilar networks into a single seamless intranet. The routing is easily configured using the ConetRouterWizard spreadsheet (see below).

### 3 Plug & Talk

The T1 CPU can automatically monitor the presence of any I/O module in the system, and, without writing a single line of programme, will automatically scan these and write the I/O values

into corresponding DIT registers for quick and easy network access. The CPU keeps a copy of the module configuration parameters in non-volatile memory so if the module requires replacement, it is instantly re-configured and updated as it should be - without user intervention.

### 4 Built-in I/O Scanner

In order to speed up network access of data, a very efficient I/O scanner reads inputs and writes outputs to the dynamic data (I/O) registers every 10ms. It also makes a live copy in the CPU's own DIT, thus making it much easier and more efficient for SCADA and other host systems. It also groups all Digital data together into a live map in the CPU, so that a single block read will collect the entire node's statuses at once. Likewise all analog data is grouped together, resulting in huge response time improvements.

The T1 CPU has also been designed for future expansion and integration with MIS systems on networks such as Ethernet.

Good technology really is transparent to the user.

### GENERAL TOPOLOGY OF CONET INTERNETWORKS USING MAXIFLEX TI ROUTER CPUs

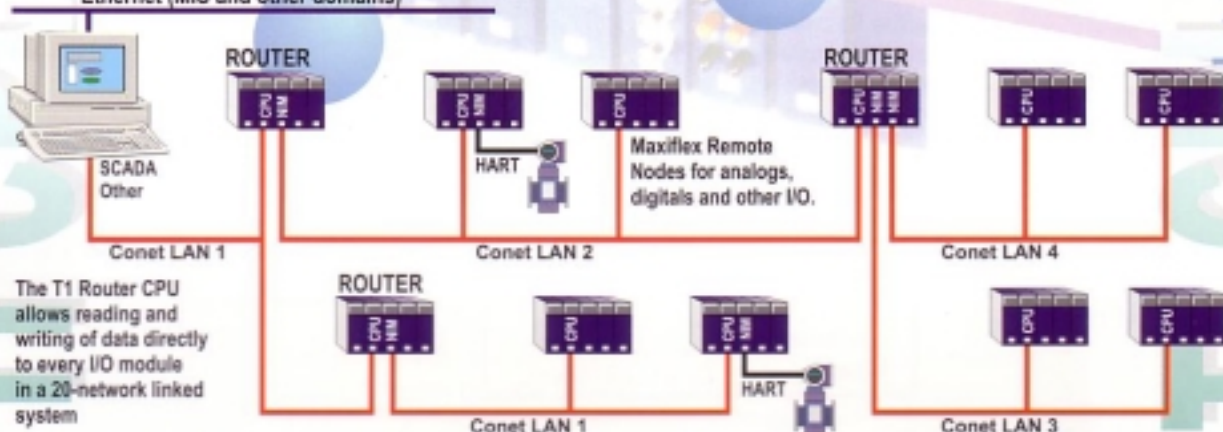

The T1 Router CPU allows reading and writing of data directly to every I/O module in a 20-network linked system

## ConetRouterWizard

Time and effort saving automatic routing table generator for Conet intranets

The introduction of internetworking on the new T1 CPU, enables complex intranets of mixed networks to be constructed, facilitating the easy flow of data between these. Because the system is more complex than a single LAN, you need more sophisticated tools to set it up. For this reason, Omnilux has developed an Excel Spreadsheet (ConetRouterWizard) which enables you to enter basic parameters that then automatically calculates what the individual inter-networking addresses must be.

It produces essential documentation for the Intranet and automatically calculates Router Table configuration values that must be set up in each DIT (Data Interchange Table). The amount of configuration work is thus reduced to an absolute minimum.

GLOBAL ID	NET 1	NET 2	NET 3	NET 4	NET 5	NET 6	NET 7	NET 8	NET 9	NET 10	NET 11	NET 12	NET 13	NET 14	NET 15	NET 16	NET 17	NET 18	NET 19	NET 20
1																				
2																				
3																				
4																				
5																				
6																				
7	Router1	128	1	128	128	75	55													
8	Router2	129	2	128	128	76	56													
9	Router3	130	3	127	127	77	57													
10	Router4	131	4	128	128	78	58													
11	Router5	132	5	129	129	79	59													
12	Router6	133	6	128	128	80	70													
13	Router7	134	7	127	127	81	71													
14		135	8	128	128	82	72													
15		136	9	127	127	83	73													
16		137	10	128	128	84	74													
17		138	11	127	127	85	75													

One of the views in the ConetRouterWizard spreadsheet, showing the automatically calculated global IDs across the connected networks.

The procedure is simple: you sketch the layout of the intranet, and identify all the access points. You then assign addresses to each point on the networks and enter these data into the ConetRouterWizard spreadsheet. In a fraction of a second, the spreadsheet calculates a complete intranet routing table - a procedure that might otherwise take you hours or days to do.

Conet just keeps getting easier!





**MORE POWER...  
...LESS MONEY**



**The NEW Powerterms...**

Full-featured, enclosed, 24Vdc switch-mode, regulated, industrial grade instrument power supplies. With a universal 4-20mA input, 90 000 hours design life, conformance to international specifications, over- and under-voltage protection, compact size, DIP solder mounting and high reliability the new Powerterms range offers you much more power and value than ever before! Over 30 years of industrial electronics design experience proves it.



Tel: (011) 2071466 Fax: (011) 2062058 email: sales@omniflex.co.za

**IT ONLY HAS  
EYES....**



**...FOR YOU**

**Omni-Watch  
The 5-in-1  
Machine Monitor**

Designed to protect large machinery, OmniWatch provides 5 vital functions in one package. It conditions inputs and shows alarm voltages, provides separate alarm and trip relay outputs, has 4-20mA retractable outputs, keeps a sequential events recorder log, and is networkable up to 10km using the popular Conet fieldbus LAN. With 1500Vrms isolation on inputs, TIC and RTD linearisation, alarm annunciator sequences, a built-in audible and self-programmability, it's the wonder you will need your own eyes anymore.

Omniflex - over 30 years industrial electronics design experience.



Tel: (011) 2071466 Fax: (011) 2062058 email: sales@omniflex.co.za

# Maxiflex Flow Application

## Reliable Pulse Totaliser System

We recently created a flow monitoring solution using Maxiflex, which overcomes two common problems on the plant: 1) existing poor quality cabling which prohibits the measurement of 4-20mA signals over long distances and 2) the availability of only digital inputs in the DCS.

The Maxiflex solution uses a Local Node near the DCS and a Remote Node near the flow transmitters, linked via Conet which can be up to 10km long, and capable of transmitting data over poor quality links.

The Remote Node converts the analog inputs into flow counts and totalises them for each of the 8 channels that it monitors. These counts are then transmitted across the Conet LAN and stored in the Local Node several times per second. The Local

Node calculates the total flow between updates, and outputs a digital bit stream from the digital output card, which is input to the DCS and then read as weighted flow pulses.

Because Conet is an ultra-long distance network (see TI CPU article for inter-networking), the flow readings can now be taken from the remotest transmitters and read in the control room with very high accuracy.

The system is protected against communication breaks, incorrect DIP switch settings and modules being replaced in the wrong slots on the Maxiflex base, in that as soon as the fault is corrected, the right amount of totaliser pulses are sent through and the DCS will be updated.

The Maxiflex Digital Flow Rate system not only saves expensive cabling from source to DCS, but also enables projects to be implemented that would otherwise be economically prohibitive.

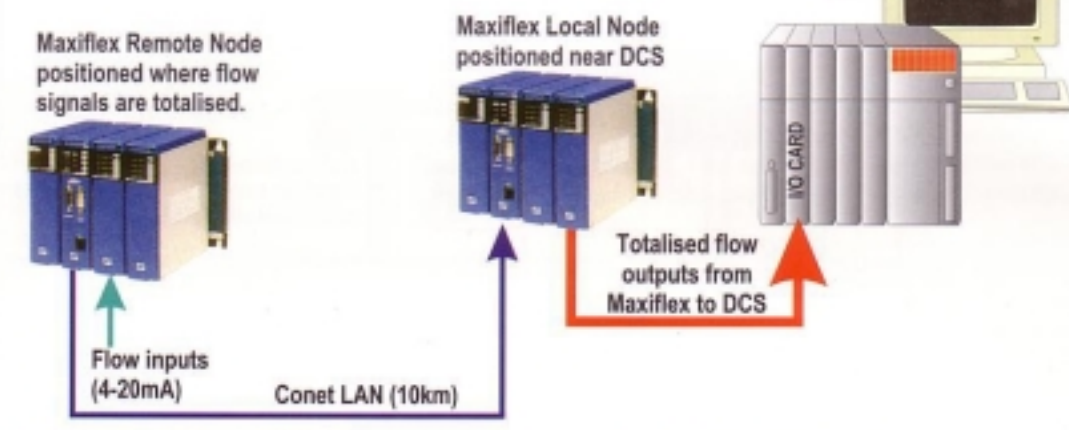

The Maxiflex flow monitoring system solves common plant problems while also saving you time and effort through its 'plug-and-talk' approach. Nothing could be simpler.



[www.omniflex.com](http://www.omniflex.com)  
[sales@omniflex.com](mailto:sales@omniflex.com)



Calling back the past: Alan Murray (left), co-founder of the original Conetlog with a handful of Microstat Logic Modules (1975) and Dave Celine with the award winning Omni-16b (1996).